

Challenge

Background

Sealing pond or river water pumps can be very challenging when external seal or packing environmental controls are unavailable. Seasonal changes in water quality can be very disruptive to seal or packing performance. Sealing options are limited when these conditions are present.

A compression packing was used with inconsistent performance and often created upstream system downtime due to gland water feed interruptions to other equipment.

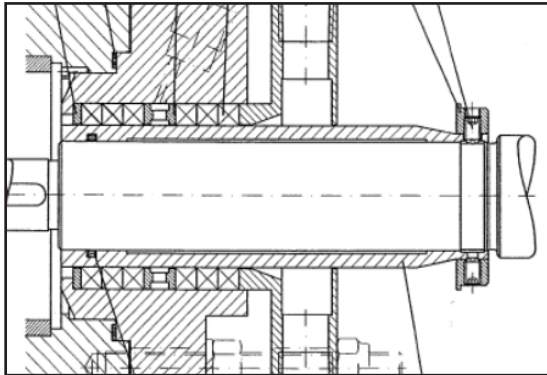

Damage from poor quality pond or river water used as flush water for traditional lantern ring packing arrangements.

Solution

Product

The compression packing and lantern ring were replaced with a **Chesterton® 180 Heavy-Duty Single Cartridge Seal** and a **SpiralTrac® Version N Type B** environmental controller, which uses the rotational flow of the pump shaft to impart a “flow” away from the seal to keep particulates out of the stuffing box.

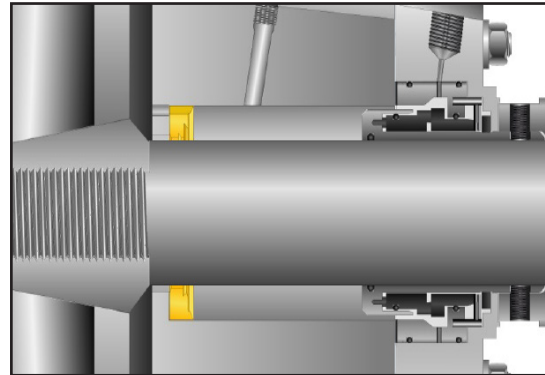

This seal arrangement is designed to run without a flush when a SpiralTrac® Version N Type B environmental controller is installed.

Results

Increased Reliability

- The mean time between repair (MTBR) increased from 3 – 6 months to 3 years+.
- Little packing adjustments and replacements needed.
- Shaft sleeve replacements were reduced significantly.
- External flush water filtering costs, and the need for external equipment was lowered.
- Upstream flush water supply was maintained.

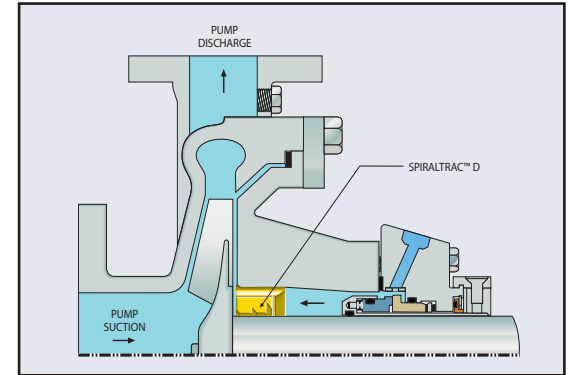

Environmental Control Plan 33H used without flush to provide a cleaner sealing environment.